

# VJ 6040 Tuning Circuit and Channel Selection

## VJ 6040 TUNING CIRCUIT AND CHANNEL SELECTION

VJ 6040 is a narrow band antenna that requires an active digital tuning circuit to allow it to cover the UHF band which spans between 470 MHz and 860 MHz.

VJ 6040 reference tuning circuit is composed of two PIN diodes that enable four channels within the UHF band. This document describes these channels, and offers a detailed description regarding how to control the tuning circuit to obtain optimal antenna efficiency.

Applications that do not require the full coverage of the UHF band can enjoy added efficiency by setting VJ 6040 to a single fixed channel.

The values described in this application note have been measured using the VJ 6040 evaluation kit.

## VJ 6040 REFERENCE TUNING CIRCUIT

The aggressive antenna miniaturization process that resulted in the ultra-small form factor of the antenna also caused the unwanted effect of reducing the antenna bandwidth to approximately 120 MHz at - 3 dBi from its peak value. Full coverage of the UHF band (470 MHz to 860 MHz) can be achieved by implementing a simple four channel active digital tuning circuit. The tuning circuit shifts the central operating frequency of the antenna, thus allowing full coverage of the UHF band.

Tuning circuit key features are:

- Small outline - fits onto a single side PCB of 5 mm x 5 mm
- Low cost BOM)
- Digitally controlled - two digital control pins enable coverage of the entire band, by offering 4 combinations
- Robust design not affected by interference sources such as GSM

## SCHEMATICS

Figure 1 presents the schematic drawing of the recommended tuning circuit.

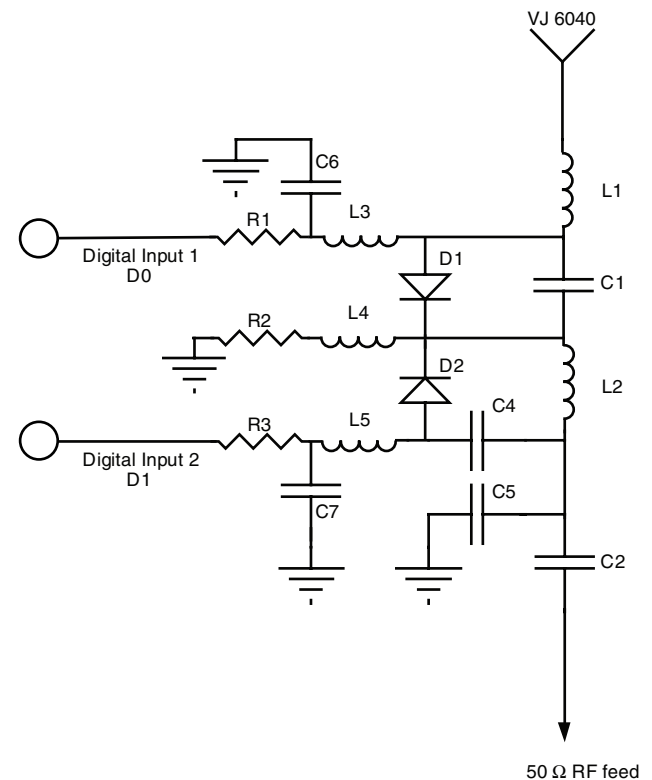

Fig. 1 - Tuning Circuit Schematics

## VJ 6040 Tuning Circuit and Channel Selection

### LAYOUT

Figure 2 shows the recommended layout of the tuning circuit. Layout should be as compact as possible.

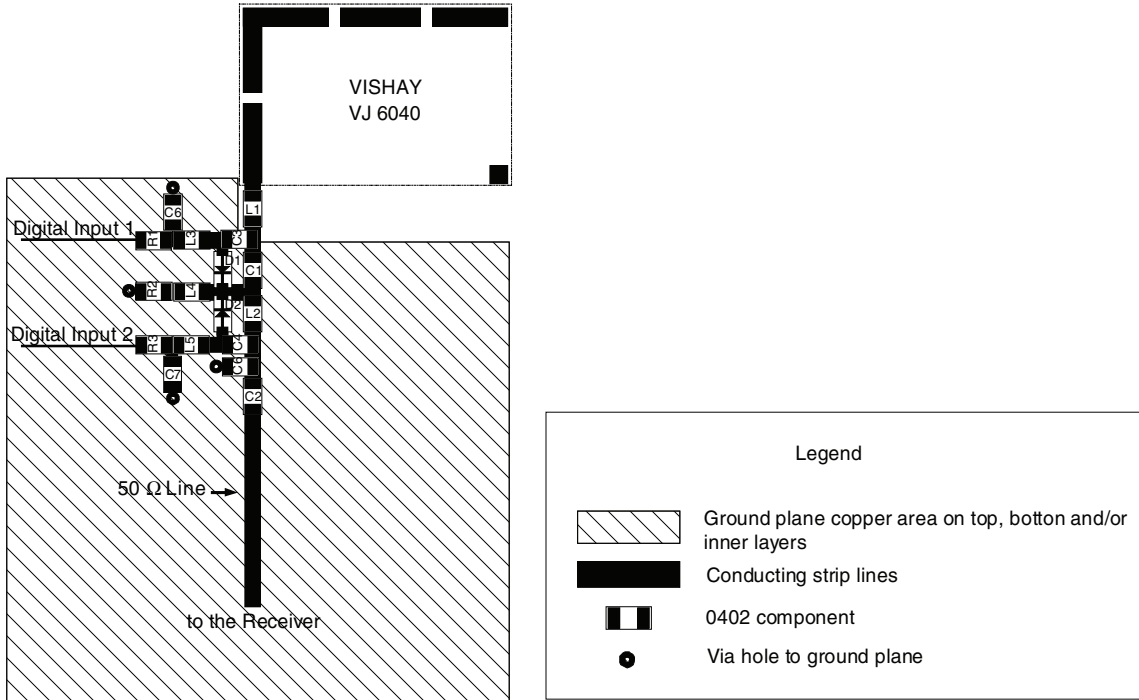

Fig. 2 - Tuning Circuit Layout

### REFERENCE TUNING CIRCUIT BOM

TABLE 1 - TUNING CIRCUIT BILL OF MATERIALS				
VALUE	REFERENCE	QUANTITY PER CIRCUIT	PART NUMBER	MANUFACTURER
120 nH	L3, L4, L5	3	HK 1005 R12J	Taiyo Yuden
PIN diode	D1, D2	2	????	Infineon
39 nH	L2	1	IMC0402ER39NJ	Vishay
47 nH	L1	1	IMC0402ER47NJ	Vishay
2.2 pF	C1, C5	2	VJ0402A2R2BXAC-W1BC	Vishay
220 pF	C2, C3, C4, C6, C7	5	VJ0402A221JXAC-W1BC	Vishay
1 kW	R1, R3	2	CRCW1KJNED	Vishay
0 W	R2	1	CRCW0R0Z0ED	Vishay

**Note**

- Any changes made in the reference BOM might result in loss of radiation efficiency.

APPLICATION NOTE

## VJ 6040 Tuning Circuit and Channel Selection

### SINGLE CHANNEL

Applications that require less than full coverage of the UHF band can remove the tuning circuit and set the antenna to a single channel centered at any point within the UHF band. The single channel tuning circuit is comprised of two components as described below:

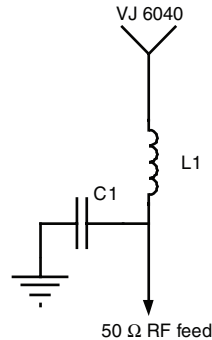
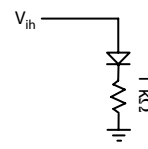
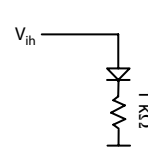

Fig. 3 - Single Tuning Circuit Layout

For example, setting VJ 6040 to a single channel centered at 725 MHz, can be achieved by assembling a 47 nH inductor at L1, and a 3.9 pF capacitor at C1. Contact Vishay Vitramon technical support for more details regarding single channel tuning circuit values.

### CONTROL SIGNAL INTEGRITY

The following table describes the desired control signal properties:

TABLE 2 - SIGNAL INTEGRITY FOR ELECTRICAL CONTROL ALTERNATIVE						
PARAMETER	SYMBOL	MIN.	TYP.	MAX.	UNITS	COMMENTS
Logical LOW	$V_{il}$	- 0.3	0	0.2	V	Equivalent DC Circuit 
Logical HIGH	$V_{ih}$	2	3	5	V	Equivalent DC Circuit 
Sink current	$I_{sink}$	0	0.01	0.05	mA	$V_{in} = - 0.3 V$ Diode reverse leakage current
Source current	$I_{source}$	4	4.2	5	mA	$V_{in} = 5 V$

#### Note

- Any changes made in the reference BOM might result in loss of radiation efficiency.

## VJ 6040 Tuning Circuit and Channel Selection

### CHANNEL CHARACTERISTICS

The two digital control lines offer four frequency channels as described in the table 3 below. This table shows the peak gain obtained in each of the four channels.

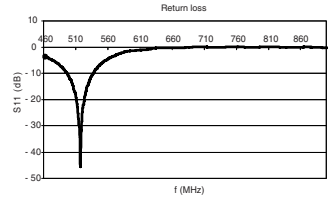
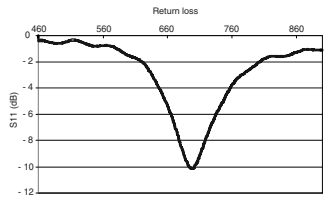
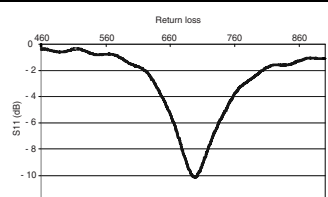
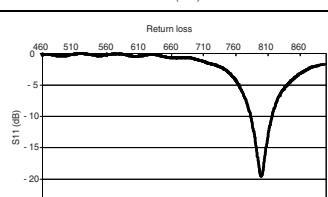
TABLE 3				
PARAMETER	D0	D1	BAND (MHz)	S11 (dB)
1	H	L	470 to 540	
2	L	L	540 to 580	
3	H	H	620 to 750	
4	L	H	750 to 860	

Features are subject to revisions or changes without notification

The company's products are covered by one or more of the following:  
 WO2008250262 (A1), US2008303720 (A1), US2008305750 (A1), WO2008154173 (A1). Other patents pending.

ORDERING INFORMATION	VISHAY MATERIAL	PACKAGING QUANTITY
VJ 6040	VJ6040M011SXISRA0	1000 pieces